

**Mikasa**

# **PLATE COMPACTOR**

**MVC-40G/50G/88G/90G/98D  
/F60/F70/F80**

**INSTRUCTION MANUAL**



We thank you for selecting Mikasa Vibration Compactor. For your safe and proper operation, please read this manual and be always sure to keep it ready for reference.



**MIKASA SANGYO CO.,LTD.**

402-03007

## 1) DECLARATION OF CONFORMITY

2) Manufacturer's name and address.	Mikasa Sangyo Co., Ltd. 1-4-3 Sarugaku-cho, Chiyoda-ku, Tokyo, Japan
3) Name and address of the person who keeps the technical documentation.	Takao Itoh, engineer R. & D. Division, Mikasa Sangyo Co., Ltd. Shiraoka-machi, Saitama, Japan
<b>4) Type: Vibratory Plates</b>	
5) model	<b>See NEXT PAGE for DETAILS</b>
6) Equipment item number	
7) power source cont. output	
8) Measured sound power level(dB)	
9) Guaranteed sound power level(dB)	
10) Max. Sound pressure level(dB)	
11) Conformity assessment according to Annex:	VIII (Full Quality Assurance procedure)
12) Name and address of the Notified Body	Société Nationale de Certification et d'Homologation (SNCH) 11, route de Luxembourg L-5230 Sandweiler LUXEMBOURG
13) Related Directive	Directive <b>2000/14/EC</b> relating to the noise emission in the environment by equipment for use outdoors.
14) Declaration	The equipment refer in this document, fulfills with all the requirements of the Directive 2000/14/EC
15) Other related Community Directives	<b>98/37/EC</b> , 89/336/EEC, 2002/88/EC EN500-4, EN500-1
16) EC Conformity Certificate No:	e13*2000/14*2000/14*0472*00
17) Place and date of the declaration	Tokyo, Japan Jan, 2007 Signed by: Mikasa Sangyo Co., Ltd.  Keiichi YOSHIDA Director, General Manager R&D Division

5) model	MVC-40G	MVC-50G	MVC-F60R (VAS)	MVC-F60H (VAS)	MVC-F70R	MVC-F70H
6) Equipment item number	52062 52064 52065 52068 52069 52070	52043 52044 52045	52184 52192 52198 52203 52221 52222	52191 52196 52218 52219	52529 52533 52538 52540 52543 52544	52530 52531 52532 52534 52546
7) power source cont. output	Robin EH09-2D 1.4kW	Robin EH12-2D 2.1kW	Robin EX13 3.2kW	Honda GX120 2.9kW	Robin EX17 4.2kW	Honda GX160 4.0kW
8) Measured sound power level(dB)	97	99	100	101	102	102
9) Guaranteed sound power level(dB)	105	105	105	105	105	105
10) Max. Sound pressure level(dB)	87	90	89	89	91	91

5) model	MVC-F70H	MVC-F80R (VAS)	MVC-F80H (VAS)	MVC-88GE (VAS)	MVC-88GH (VAS)	MVC-98D (VAS)
6) Equipment item number	52530 52531 52532 52534 52546	52567 52568 52569	52564 52565	52363 52383 52390	52367 52370 52371 52373 52374 52391 52395 52396	52385 52386 52387 52388 52389
7) power source cont. output	Honda GX160 4.0kW	Robin EX17 4.2kW	Honda GX160 4.0kW	Robin EX17 4.2kW	Honda GX160 4.0kW	Yanmar L48A 3.5kW
8) Measured sound power level(dB)	102	104	102	102	104	104
9) Guaranteed sound power level(dB)	105	105	105	105	105	108
10) Max. Sound pressure level(dB)	91	94	94	94	94	96

#### Hand-Arm Vibration Level

Model	Ahv (m/sec <sup>2</sup> )
MVC-40G	5.4
MVC-50G	6.9
MVC-F60H	7.3
MVC-F60R	7.0
MVC-F70H	5.8
MVC-F70R	6.3
MVC-F80H	6.7
MVC-F80R	7.0
MVC-88GH	4.7
MVC-88GE	4.8
MVC-98D	4.4
MVC-F60H VAS	3.3
MVC-F60R VAS	3.2
MVC-F80H VAS	3.8
MVC-F80R VAS	3.5
MVC-88GH VAS	2.1
MVC-88GE VAS	1.7
MVC-98D VAS	2.0

#### Remarks

Vibration Level is in comply with EU Directive 2002/44/EC and the value is shown as 3 axis min. vibration level. Test course ( Crushed gravel ) is in comply with EN500-4.

The above values are subject to change in case that the machine is modified or/and the required regulations change.

# SPECIFICATIONS

Model	MVC-40G	MVC-50G	MVC-F60R ( VAS )	MVC-F60H ( VAS )	MVC-F70R	MVC-F70H	MVC-F80H ( VAS )	MVC-88GH ( VAS )	MVC-88GR	MVC-88GE ( VAS )	MVC-90G	MVC-90BG	MVC-98D ( VAS )
<b>Dimensions</b>													
Overall Length	mm	855	905 ( 930 )	905 ( 930 )	905	905	915 ( 930 )	1100 ( 1050 )	1100	1100 ( 1050 )	1160	1160	1100 ( 1050 )
Overall Width	mm	290	350	350	420	420	450	500	500	500	500	500	500
Overall Height	mm	920	860 ( 1000 )	860 ( 1000 )	860	860	860 ( 1000 )	825 ( 950 )	825	825 ( 950 )	720	720	825 ( 950 )
Plate Size (W X L)	mm	420 x 290	510 x 350 (570x350)	510 x 350 (570x350)	510 x 420	510 x 420	570 x 450	525 x 500	525 x 500	525 x 500	560 x 500	560 x 500	525 x 500
<b>Weight</b>													
Operating Weight	kg	46	74 ( 77 )	73 ( 76 )	81	81	87 ( 90 )	96 ( 99 )	98	96 ( 99 )	89.5	81	108 ( 111 )
<b>Performance</b>													
Travelling Speed	m/min	25	25	25	25	25	25	25	25	25	25	25	25
Vibrating Frequency	Hz(vpm)	103 (6200)	93 (5600)	93 (5600)	93 (5600)	93 (5600)	93 (5600)	100 (6000)	100 (6000)	100 (6000)	96 (5800)	97 (5800)	100 (6000)
Centrifugal Force	kN(kgrf)	7.2 (730)	10.1 (1030)	10.1 (1030)	12.0 (1220)	12.0 (1220)	13.7 (1400)	15.0 (1530)	15.0 (1530)	15.0 (1530)	15.2 (1550)	15.2 (1550)	15.0 (1530)
Vibrating unit		SAE 10W-30	SAE 10W-30	SAE 10W-30	SAE 10W-30	SAE 10W-30	SAE 10W-30	SAE 10W-30	SAE 10W-30	SAE 10W-30	SAE 10W-30	SAE 10W-30	SAE 10W-30
Lubrication oil in vibration case	cc	300	140	140	140	140	140	200	200	200	140	140	200
Water tank capacity	liters	-	11	11	11	11	13	13	13	13	5.3	-	13
V-Belt Size		RPF3270	RPF3310	RPF3310	RPF3310	RPF3310	RPF3310	RPF3330	RPF3330	RPF3330	A-34	A-33	RPF3380
<b>Power Source</b>													
Manufacturer		Robin	Robin	Honda	Robin	Honda	Honda	Honda	Robin	Robin	Robin	Robin	Yanmar
Model		EH09-2D (petrol)	EX13D (petrol)	GX120 (petrol)	EX17D (petrol)	GX160 (petrol)	GX160 (petrol)	GX160 (petrol)	EH17-2D (petrol)	EX17D (petrol)	EY20-3D (petrol)	EY20-3D (petrol)	L48AD(diesel)
Max. Output		2.1kW(2.8PS) /4200min <sup>-1</sup>	3.2kW(4.3PS) /4000min <sup>-1</sup>	2.9kW(4.0PS) /4000min <sup>-1</sup>	4.2kW(5.7PS) /4000min <sup>-1</sup>	4.0kW(5.5PS) /4000min <sup>-1</sup>	4.0kW(5.5PS) /4000min <sup>-1</sup>	4.0kW(5.5PS) /4000min <sup>-1</sup>	4.0kW(5.5PS) /4000min <sup>-1</sup>	4.2kW(5.7PS) /4000min <sup>-1</sup>	3.7kW(5.0PS) /3600min <sup>-1</sup>	3.7kW(5.0PS) /3600min <sup>-1</sup>	3.5kW(4.7PS) /3600min <sup>-1</sup>
Fuel Tank Capacity	liters	1.5	2.7	2.5	3.6	3.6	3.6	3.6	3.6	3.6	3.8	3.8	2.4
Lubricant capacity	cc	300	600	600	600	600	600	600	600	600	600	600	800
Starting system		Recoil starting	Recoil starting	Recoil starting	Recoil starting	Recoil starting	Recoil starting	Recoil starting	Recoil starting	Recoil starting	Recoil starting	Recoil starting	Recoil starting
Set R.P.M	rpm	4000	3600	3600	3600	3600	3600	3600	3600	3600	3500	3500	3600

# Plate Compactor

## Application

Plate compactor is the machine that compacts the ground and it intends to make the surface smooth, by transmitting vibration through vibrating plate, which power generated from single rotor in vibrator case. This machine is suitable for making the ground surface smooth, such as leveling the soil and beaching, finishing the asphalt paving.

## Warnings for incorrect application and abuse

This machine is hard to move forward on a soil with much water (especially clay soil). It is not suitable for such application. This machine is difficult to level a ground include big stones due to insufficient compacting force. Plate compactor is mainly applied for compacting surface smooth and it is not effective for jobs that requires heavy compaction. In case of compacting ground deeply into lower layer, it is recommended to use Tamping Rammer, Vibro Compactor and Vibration Roller which compacting force is rather effective. Please use this compactor for compacting surface on soil, sediment, sand, beaching and asphalt. It is not recommended for use this machine for the other applications.

## Structure

The upper part is made up of Power source, Handle, Belt Cover, Water Tank for sprinkling and Guard hook which are fixed by Engine base. The Engine base is fixed on Vibrating Plate by Shock absorbing Rubber. The lower part is made up of Vibrating plate and Vibrator unit that has an Eccentric rotary shaft built in. The power source is transmitted from the centrifugal clutch on engine output shaft to the Eccentric rotary shaft via V-belt.

## Power Transfer

Air-cooled Single cylinder Engine is mounted as power source and Centrifugal Clutch is fixed on engine output shaft. Petrol Engine (2 cycle, 4 cycle) and Diesel Gasoline Engine can be mounted as option.

Centrifugal Clutch engages by running up the engine and engine R.P.M. is reduced to suitable number for compacting. The rotation of engine is transmitted from V-pulley integrated with Clutch drum to Vibrator pulley through V-belt.

Vibrator Pulley rotates Eccentric rotor shaft that is contained in Vibrator case. The generated vibration created from eccentric rotor is transmitted to Compacting plate.

Vibration of Vibrating Plate carries the machine forward; the vibration with the weight of the machine makes the compaction of the ground possible.

# FOR SAFETY OPERATION

## Foreword :

It is important to read this manual carefully so that you will fully understand the operational characteristics and performance of the plate compactor. Proper maintenance procedures will insure long life and top performance of the unit.

## Safety:

This section outlines basic safety procedures that apply to the operation, maintenance and adjustment of the Mikasa plate compactor. This unit is designed as a powerful, productive machine that should be operated with respect and caution.

Misuse or carelessness can result in serious injury or property damage, or both. Safety precautions must be observed at all times.

-  This safety alert symbol identifies important safety messages throughout this manual and on the machine. When you see this symbol, carefully read the message that follows. Your safety is at stake!

## Operator Qualifications:

Before operating this equipment, an individual should read this manual. Whenever possible, he should be shown how to operate the unit by an experienced operator. Inexperience is hazardous in operating any machine or attachment. Trial and error is not the way to become familiar with a piece of equipment. This is expensive, cuts equipment life and can create machine downtime. Inexperience can cause injury or death. The machine should not be left unattended when operating.





## General Safety:

-  **CAUTION**  
Protection required. Wear hard hat, shatterproof glasses, steel toed boots and other protective devices required by job conditions. Avoid jewelry or loose clothing. These may catch on controls or in moving parts and cause serious injury.

## Starting Safety

-  **CAUTION**  
Poisonous fumes. Start and operate only in well ventilated area. Breathing exhaust gases can result in sickness or death.

## Servicing Safety:

-  **CAUTION**
-  Flammable liquid. Stop engine and do not smoke or allow work in immediate area when refueling. Fire or explosion could result from flames or sparks.
-  Moving parts. Shutdown engine before performing service or maintenance. Contact with moving parts can cause serious injury.
-  High temperature. Allow machine and engine to cool before performing service or maintenance. Contact with hot components can cause serious burns.

## Engine

See engine operations manual

## SHUTDOWN

### EMERGENCY SHUTDOWN

Move throttle lever to "OFF" position and also turn stop switch to "OFF".

### NORMAL SHUTDOWN

Move throttle lever quickly from "ON" to "OFF" and run engine for 3 to 5 minutes at low speed. After engine cools, turn stop switch to "OFF" position. Close fuel shutoff valve.

## 1. Prior to operation

- 1-1. Make sure that all dirt, mud, etc., are thoroughly removed from the unit prior to operation. Special effort should be given to the bottom face of the vibrating plate and those areas adjacent to the cooling air inlet of engine, carburetor, and air cleaner.
- 1-2 Check all bolts and screws for tightness and make sure all bolts and screws are securely tightened. Loose bolts and screws may cause damage to the unit.
- 1-3 Check the V-belt for tightness. The normal slack should be approximately 10-15mm (1/2") when the belts are forcibly depressed in the middle position between the two sheaves.  
If there is excess belt play, there could be a decrease in the impact force or erratic vibration, causing machine damage.
- 1-4 Check the engine oil level and if the engine oil level is low, it should be refilled. Use the proper motor oil as suggested in the table below. (Fig-1)
- 1-5 Remove the oil plug in the vibrator assembly and check the oil level. Make sure the compactor is level when checking. The oil level should be up to the oil plug. Every month or every 200 hours of operation, replace the oil. (Fig - 2)

### IMPORTANT:

Use the Motor oil SAE

When changing the oil, the old oil can be drained by tipping the unit.

The oil will drain easily while it is hot.

- 1-6 A regular grade gasoline should be used in the engine.  
When filling the fuel tank, make sure the fuel filter is used.

## 2. Caution

- 2-1 Be careful with the operating place and ventilation.  
Avoid operating the machine in a closed room, tunnel, or other badly ventilated places, since its exhaust contains deadly poisonous carbon monoxide. If the machine is employed unavoidable operated in such a place, discharge the exhaust outside the room by a suitable means.
- 2-2 Be careful with the hot members.  
Mufflers and other hot members are dangerous. Do not touch them with unprepared hand.
- 2-3 Observe with the following cautions when transporting. Clamp fuel tank cap securely, and turn the fuel valve OFF at the source during transportation.  
Drain gasoline from fuel tank before transporting over a long distance or on rough roads.

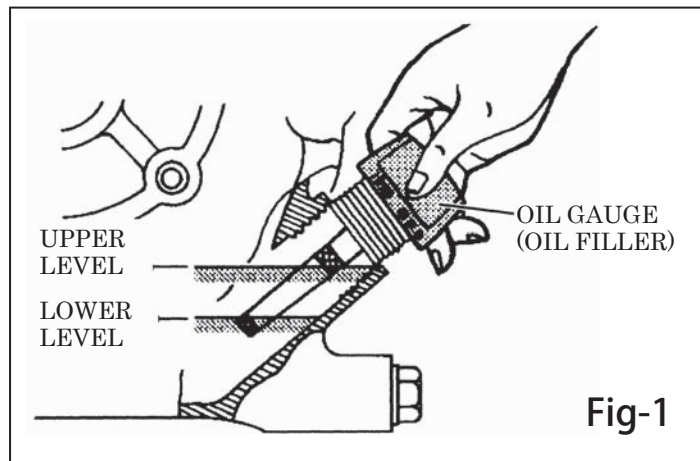
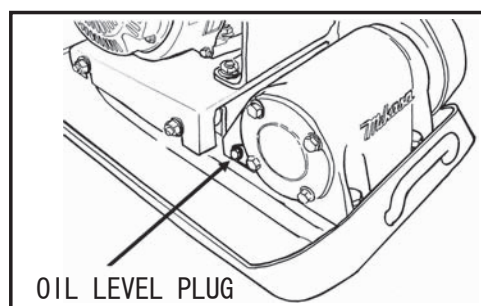

Fig-1

Season or Temperature	Grade of Motor oil (higher than MS class)
Spring, Summer or Autumn +120° F to +40° F	SAE 30
Winter +40° F to +15° F	SAE 20
Below +15° F	SAE 10W-30



MVC-F60, F70

Fig-2A

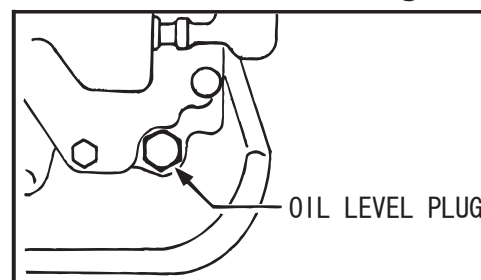

MVC-88G

Fig-2B

- 2-4 Stop engine without fail before replenishing fuel tank.  
Never replenish gasoline while the engine is running or remains hot otherwise spilled or evaporated fuel is liable to catch fire from engine sparks or muffler heat.  
Wipe off spilled fuel, if any, before starting engine.  
Be careful not to spill fuel.
- 2-5 Keep inflammables away from the vicinity of the exhaust port.  
Be careful with gasoline match, straw and other inflammables, since the exhaust port is subjected to a high temperature.

### 3.Starting

#### Gasoline Engine

- 3-1 Turn the STOP SWITCH clock-wise to the position "I"(ON). Fig.3
- 3-2 Open the fuel cock. Fig.4
- 3-3 Set the speed control lever 1/3 to 1/2 of the way towards the high speed position Fig.5
- 3-4 Close the choke lever.
- If the engine is warm or the ambient temperature is high, open the choke lever half-way, or keep it fully open.
  - If the engine is cold or the ambient temperature is low, close the choke lever fully. Fig.6
- 3-5 • Pull the starter handle slowly until resistance is felt. This is the "compression" point. Return the handle to its original position and pull swiftly.
- Do not pull out the rope all the way.
  - After starting the engine, allow the starter handle to return to its original position while still holding the handle. Fig.7

#### Diesel Engine

- 3-6 Turn the throttle lever to START position ( open by about 30 degrees ) ( Fig-5-D )
- 3-7 Operate Starter
- In case of recoil starter
- By pulling the starter knob slowly, you will reach such point where resistance become strong ( compression point ). By pulling it further, you will find a point where resistance is reduced. Return the knob but slowly return it original position. ( Fig.7-D )
- ⚠ CAUTION**  
Do not pull the rope all the way and do not take your hand off the pulled knob but slowly return it original position.
- 3-8 After starting up the engine, be sure to perform a warm up run for 2 to 3 minutes. This should be performed without fail, particularly during winter season. While doing this, check for abnormal sound of gas leaking.

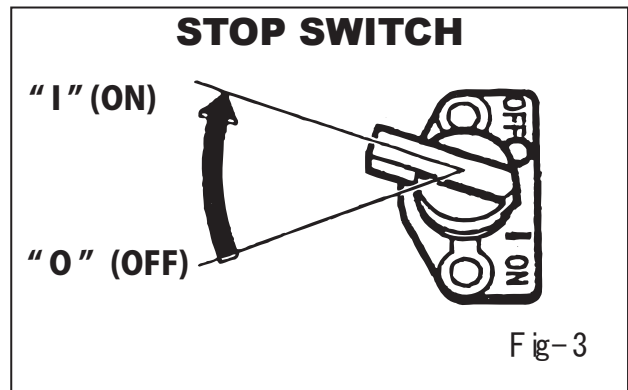

Fig-3

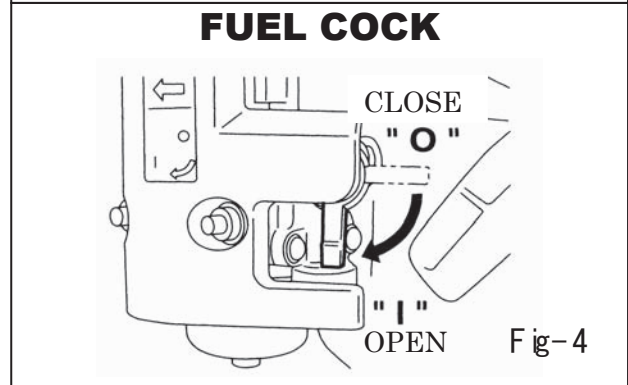

Fig-4

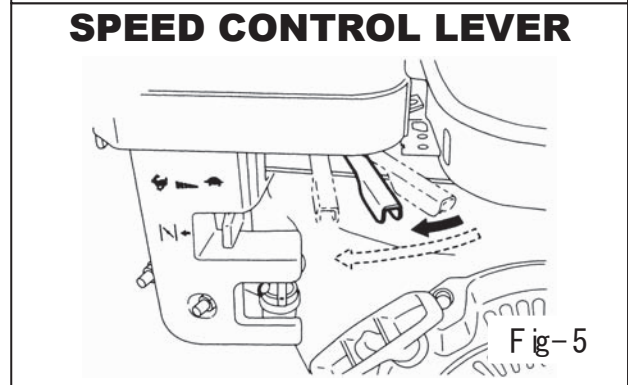

Fig-5

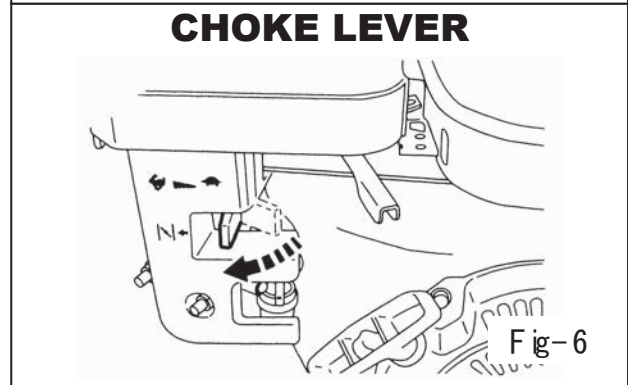

Fig-6

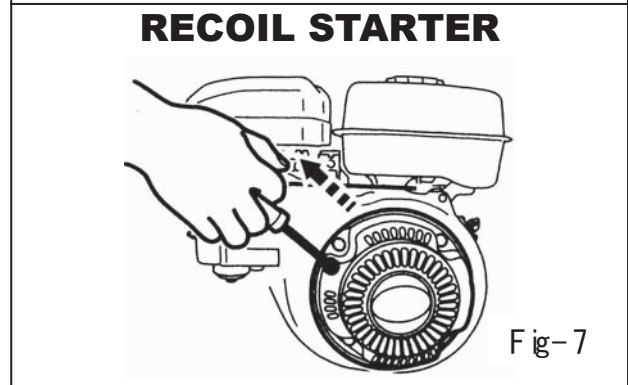
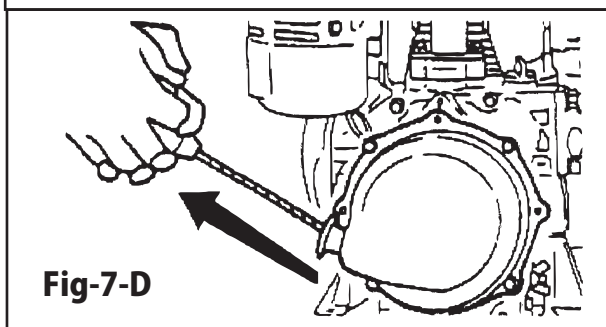
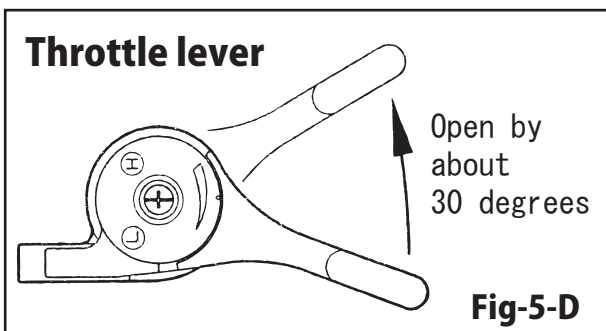

Fig-7





## 4. Operation

- 4-1 As the engine warms up, gradually move the choke lever to the OPEN position. (Fig-8)
- 4-2 Move the speed control lever from the LOW to the HIGH position. When the engine speed reaches approximately 2,300-2,600 RPM, the centrifugal clutch engages. If the engine speed increased very slowly, it is possible that the clutch can slip. Do not operate the speed control lever slowly. (Fig-9,10)

### OIL ALERT SYSTEM

The Oil Alert System is designed to prevent engine damage caused by an insufficient amount of oil in the crankcase. Before the oil level in the crankcase can fall below a safe limit, the Oil Alert System will automatically stop the engine (the engine switch will remain in the ON position).

### NOTICE

If the engine stops and will not restart check the engine oil level.

- 4-3 When compacting asphalt, it is advisable to paint the bottom face of the vibrating plate with diesel fuel. This will assist in preventing the plate from sticking to the asphalt.
- 4-4 When shutting off the vibrator, turn the speed control lever from the HIGH to LOW position. Do not move the speed control lever slowly.
- 4-5 Water spring system  
The water system will provide about 20 minutes sprinkling with the water cock in the fully open position and the compactor operating at full speed. It is advisable to mix a small amount of detergent or diesel fuel with the water.  
This will allow the water to flow easier.

## 5. Transportation

- 5-1 Be sure to stop the engine while transporting.
- 5-2 Screw up the fuel tank cap securely and close the fuel valve to avoid fuel leaking.
- 5-3 In transportation by car, fix machine securely not to move nor to fall down.  
In case of driving for long distance or at off-road, take out fuel from tank.

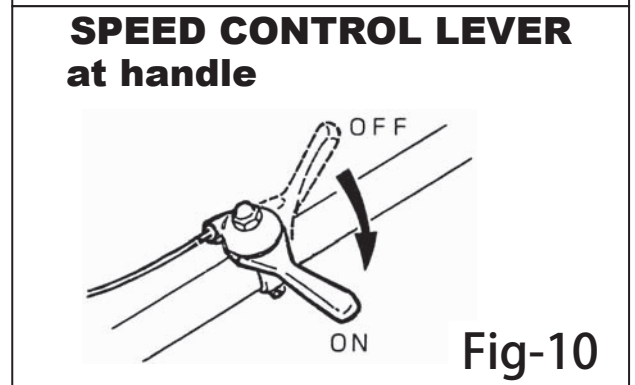
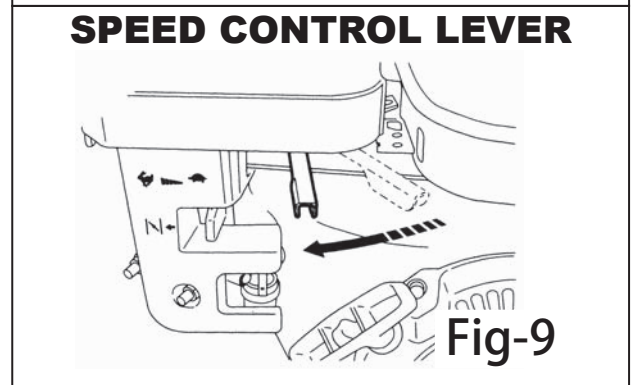
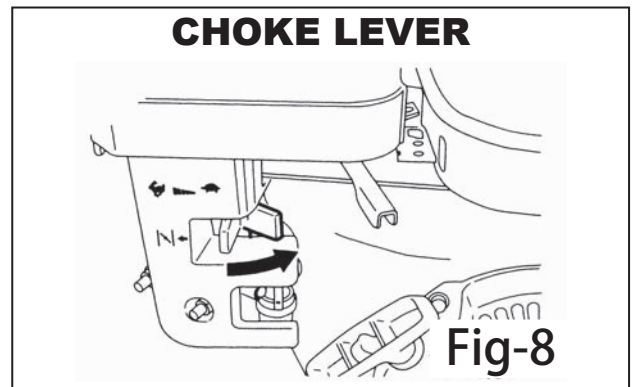

## 6.Shutdown

To stop the engine in an emergency, turn the stop switch to the OFF position.

Under normal conditions, use the following procedure:

- 6-1 Set the speed control lever at the low speed position and allow the engine to run at low speed for 2 or 3 minutes before stopping.
- 6-2 Turn the stop switch to the OFF position (Fig-12)
- 6-3 Close the fuel cock. (Fig-13)
- 6-4 If the water system was being used, close the cock on the water tank.

## 7. Service & storage

### ⚠ CAUTION

Flammable liquid : Stop engine and do not smoke or allow work in immediate area when refueling. Fire or explosion could result from flames or sparks.

Moving parts : Shutdown engine before performing service or maintenance. Contact with moving parts can cause serious injury.

High temperature : Allow machine and engine to cool before performing service or maintenance. Contact with hot components can cause serious burns.

### 7-1 Daily Service

- A.Remove mud, dirt, etc.,from the unit.
- B.Clean bottom face of the vibrating plate
- C.Check the air cleaner element and clean if necessary.
- D.Check all nuts, bolts, and screws for tightness and retighten as necessary.

### 7-2 Weekly Service

#### A.AIR CLEANER SERVICE (Fig-14)

Dirty air cleaner element will cause starting difficulty, power loss, engine malfunctions, and shorten engine life extremely.

Keep the air cleaner element clean.

#### ● Urethane Foam Element

Remove the element and wash it in kerosene or diesel fuel. Then saturate it in a mixture of 3 parts kerosene or diesel fuel and 1 part engine oil.

Squeeze the element to remove the mixture and install it in the air cleaner.

#### ● Urethane Foam Dual Structure

- 1.Clean the urethane foam in the same way as described above.
- 2.Wash the element in kerosene or diesel fuel. Saturate it in a mixture of 3 parts kerosene or diesel fuel and 1 part engine oil. Shake off excessive oil and reinstall.

## SPEED CONTROL LEVER

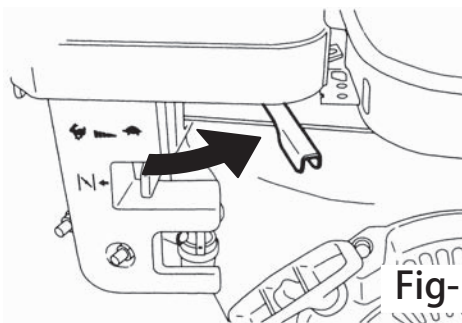

Fig-11

## STOP SWITCH

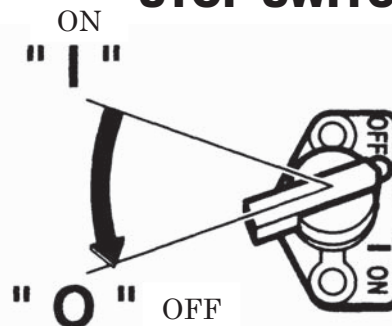

Fig-12

## FUEL COCK

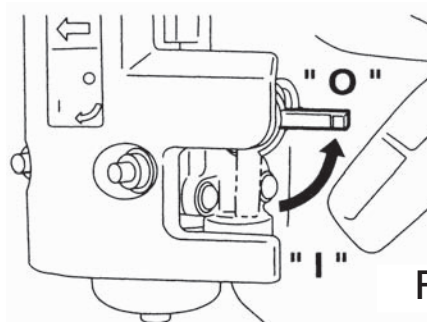

Fig-13

## AIR CLEANER

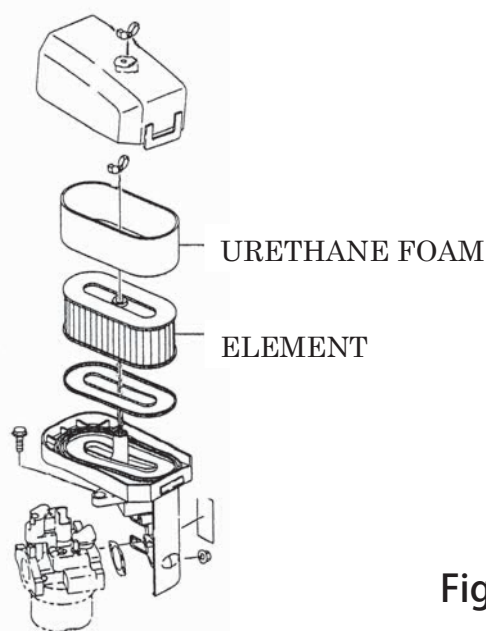

Fig-14

B.Remove spark plug, clean and adjust the spark plug gap to 0.6-0.7mm(0.02-0.03 in.). (Fig-15)

C.Drain the motor oil of the engine and replace with new specified oil. (Fig-16)

NOTE:When the engine is new, the first oil change must be made after 20 hours of Operation.

### 7-3 Monthly Service

Change the Oil in the vibrator assembly.

### 7-4 Storage

When storing the compactor for long periods after operation.

A.Thoroughly drain the fuel from the fuel tank fuel pipe and carburetor.

B.Pour a few drops of motor oil into the cylinder by removing the spark plug.

Rotate the engine several times by hand so that the cylinder interior is covered with oil.

C.Clean the outer surface of the machine with an oil moistened cloth. Cover the unit and store in a humidity-free, dust-free area.

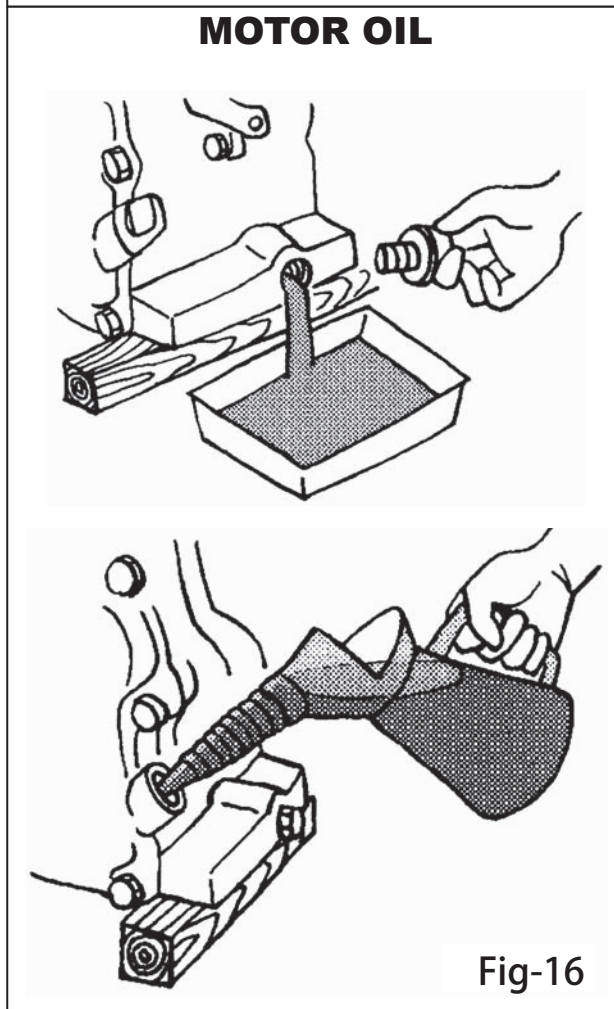
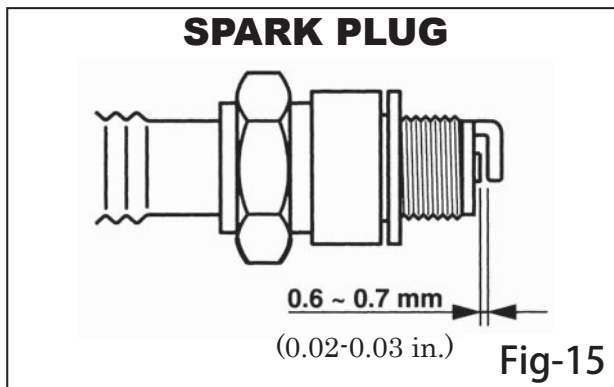



**MIKASA SANGYO CO.,LTD.**

HEAD OFFICE

NO. 4-3. 1-CHOME, SARUGAKU-CHO, CHIYODA-KU

TOKYO, JAPAN

(402-03006)07-04-500(OG)  
(402-03001)05-04-300(OG)